

Product Specifications			
Model	MF1500	MF2000	MF3000
Freq./Volt	120V/60Hz		
Power	25W	35W	40W
Max. Flow	400GPH	550GPH	850GPH
Max. Headheight	6ft	8ft	9ft
Hose Adapters	3/4"	3/4"	3/4"

### 1 YEAR STANDARD WARRANTY

This product is guaranteed for defective parts and workmanship for a period of 1 year from the date of purchase. This guarantee is valid with proof of purchase only. The guarantee is limited to repair or replacement only and does not cover consequential loss, loss or damage to livestock and personal property or damage to animate or inanimate objects, irrespective of the cause thereof. This guarantee excludes any damage caused by unreasonable use, negligence, improper installation, tampering, abuse or commercial use.

Customer Service: [aquamiraclesales@gmail.com](mailto:aquamiraclesales@gmail.com)

# Instruction Manual

Pond Fountain Kit  
MF1500 / 2000 / 3000

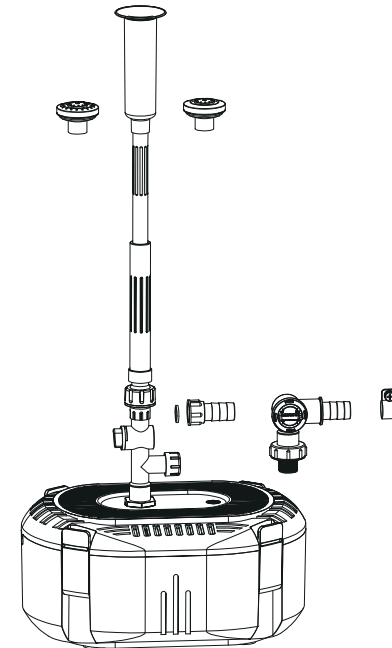

Fountain



Filtration

Thanks for buying our pond fountain. To ensure you use the product safely and correctly, please read carefully and thoroughly this instruction.

Please note that we are not responsible for any failure caused by misuse or improper maintenance.

**SAVE THIS INSTRUCTION FOR FUTURE USE.**

## **Important Safety Precautions**

---

1. Please operate the appliance under the rated voltage and frequency indicated on the rating label or instruction manual.
2. A 10mA or 30mA residual current device must be fitted to the mains supply.
3. The power cord is not replaceable. If the power cord or the plug is found hurt or damaged, or the plug is found aged, stop using the pump immediately. Return the pump to the retailer / distributor for disposal, or dispose it by yourself.
4. Do not attempt to shorten the power cord, or to remove the plug. Failure to meet this point may cause damage to the pump.
5. If abnormal smell or noise is found to the pump, unplug it immediately and check the cause. Contact your retailer / distributor if needed.
6. Make sure your hand and the plug are dry when plug in or unplug the pump. It is forbidden to plug or unplug the pump with a wet hand as this might cause electric shock.
7. Unplug the pump before installation and cleaning. Don't pull the power cord abruptly. To unplug, grasp the plug and pull it out from the receptacle.
8. Protect properly the pump. If severe collision happens to the pump, check if there is any damage. If there is any breakage, stop using the pump and destroy it.
9. Do not let the pump run dry as this will damage the rotor and will cause over-heating of the motor.
10. Do not operate or leave the pump in freezing conditions.
11. Do not use the pump in inflammable or corrosive liquids. The pump should work in the environment less than 35 °C (95F).

## **Winter Storage**

This fountain kit can be run in the pond during the winter but care should be taken to ensure that it is fully immersed and cannot freeze solid. If it is not used during the winter, fully clean the components and store frost-free in the house or garage until spring.

## **Optional Upgrade Accessories (should buy separately)**

---

This fountain kit can be upgraded to have 2 more functions:

**Algae Removal** – Install our UV lamp into the filter box. If you have an issue with algae bloom (green water), you are strongly suggested to add the UV lamp to your filter box. The UV lamp can be easily installed to the filter box (The place reserved for the UV lamp is at the down side of the pump locating plate)

**LED Light** – Our colorful LED fountain light comes with a remote control to light up your fountain, which will make your fountain more enjoyable at night! Choose the preferred color or color change mode with the remote control. The LED light is fully water-proof and can be easily installed onto the fountain jet.

**Reminder – Only buy our UV lamp and LED fountain light specifically designed for this product. They are available online.**

## **Troubleshooting**

---

### ***The pump doesn't pump water***

- The pump is not started up.
- The power doesn't match the voltage and frequency specified on the pump.
- Water inlet or outlet is blocked.
- Impellor or rotor is damaged.

### ***Water flow is reduced***

- The voltage is lower than the rated voltage.
- Wastes are accumulated in the filtering system and the sponges needs to be cleaned.
- Impeller or rotor gets worn out and needs to be replaced.

### ***The pump is noisy***

- Water inlet is partially blocked.
- Water level is lower than the inlet of the pump. Air enters into the pump to cause noise.
- Rotor is worn (need to be replaced)

Seek for your local retailer / distributor's help if the above troubleshooting can't resolve the problems.

## Maintenance

### How often should the maintenance to be implemented?

It depends on the environment in your pond. If obvious loss of flow is observed to the fountain, it is time to do the maintenance, in most of the time you only need to clean or replace the filter sponge.

Whatever, you should at least do a through maintenance to the pump once a year.

### Filter Sponge

Open the filter box, clean the sponges with running clean water.

When installing back, make sure the sponges are in the correct order – the coarse (blue) sponge is on the top and the fine (yellow) sponge is at the bottom.

### Ceramic Rings / Bio Balls

Special attention should be taken to the maintenance of the ceramic rings and bio balls.

Ceramic rings and bio balls provide great environment for the growth of the beneficial bacterial, which helps maintain a healthy biological environment in your pond.

DO NOT clean the ceramic rings and bio balls too often. Suggest only do the cleaning **once a year**.

Only use **water from the pond** to do the cleaning to ensure the beneficial bacterial not been killed by fresh new water.

### Water Pump

This pump is free from lubricants or special maintenance. However, to keep the pump operates in the best condition, regular maintenance and cleaning is needed. It is recommended to maintain the pump at least **once half year**. However, if loss of flow is found to the fountain, and cleaning of the sponges still can't resolve the problem, the water pump should be maintained.

**Do not pull the power cord to lift the pump as this may cause damage to the power cord.**

To clean the pump, follow the steps above to open the filter box cover, and take out the sponges.

1. Take the water pump out from the filter box.

2. Remove the impeller cover (the part connecting to the elbow) by turning counterclockwise to release the lock. Gently pull away the impeller cover from the motor body. Make sure the O-rings are not missed.



3. Carefully take out the impeller/rotor assembly.

4. Wash out all of the components in clean water. Do not use detergents or other chemical cleaners.

5. Reassemble the pump in the reverse order.

- For wearing parts like the impellor kit, approach the local retailer / distributor for replacement. You need to pay for the wearing parts if the pump has been used for over 1 year.

## Product Structure Diagram

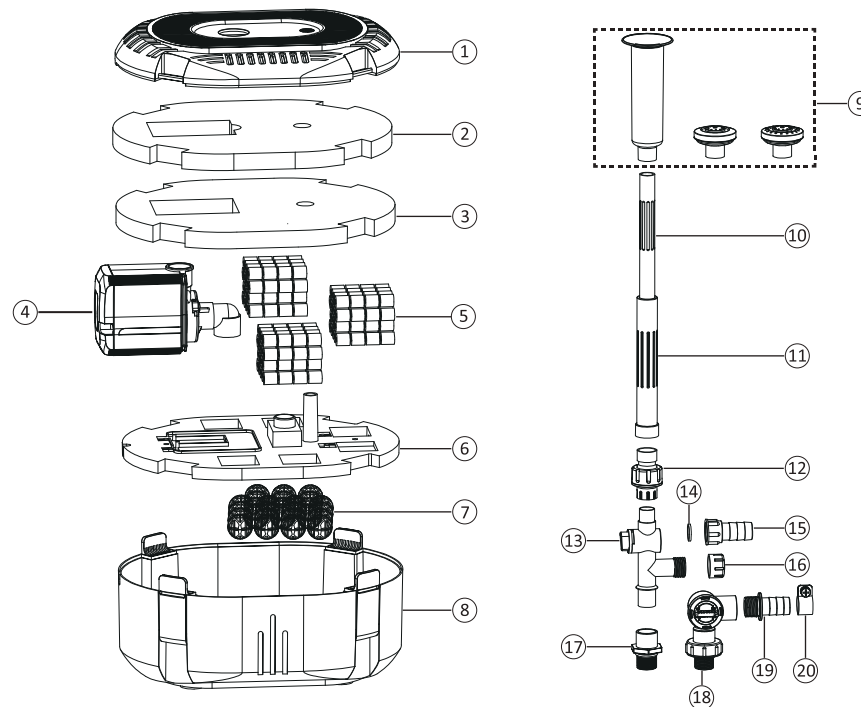

### Components:

1-Filter box cover

2-Coarse filter sponge (blue)

3-Fine filter sponge (yellow)

4-Water pump

5-Ceramic rings (3 bags)

6-Pump locating plate

7-Bio balls

8-Filter housing

9-Fountain jets (3 types – daisy / bell / volcano)

10-Telescopic tube – small

11-Telescopic tube – big

12-Ball joint

13-T piece with flow control

14-Sealing ring

15-Hose adapter

16-Diverter stopper

17-Adapter for fountain jets

18-Connector (to pump)

19-Hose adapter

20-Hose clamp

## Assembly

1. Take all the components out. Make sure no components are missed according to the diagram above.

2. Clean the components.

- Release the cover of the filter box by pulling the 4 corner lock buckles outward.



- Tear off the protecting bag of the ceramic rings. Then put the ceramic rings into the net bag.
- Rinse all the components with clean running water.

3. Assemble the filter box.

- Put the bio balls into the filter box.
- Put the pump locating plate back into the filter box.
- Install the pump. Make sure the pump sits on the pump locators (the pins on the plate), and the inlet elbow couples with the extruded water inlet tube.
- Put the 3 bags of ceramic rings at the surrounding of the water pump. Suggest putting a bag at the left / right / front side each of the water pump respectively.
- Put the sponges on the top of the pump. Make sure the coarse (blue) sponge is on the top and the fine (yellow) sponge is underneath.
- Put the filter box cover back and lock with the 4 corner lock buckles by pressing the locks inward.

4. Assemble the fountain jet.

Follow the diagram below for the installation.

- Install Part A first. Screw the adapter to the outlet of the pump, then press fit Part A to the adapter.
- Press fit Part B to Part A.
- Press fit the fountain jet (Part C - choose one from the 3 jets) to the small tube of part B.

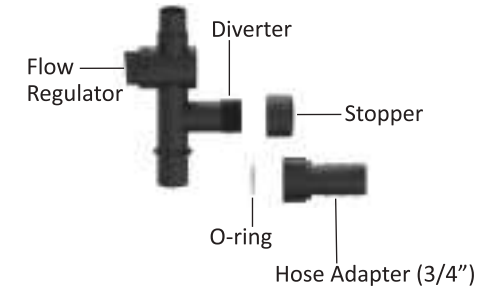
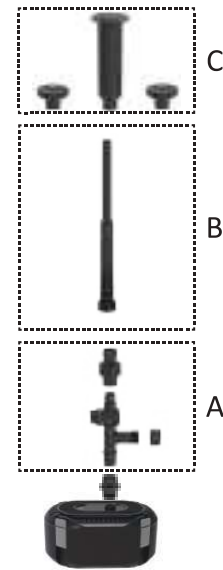

**The Diverter Set**

5. Important Notes.

- The tubes are telescopic. Adjust the fountain to the desired height by adjusting the tubes.
- The flow regulator on the T piece can adjust the flow rate of the pump.
- The diverter on the T piece. The diverter allows the kit to run both the fountain and a water feature.

To make this function work, replace the stopper with the hose adapter. Connect to a hose to introduce water to the water feature. (Refer to the fig. above)

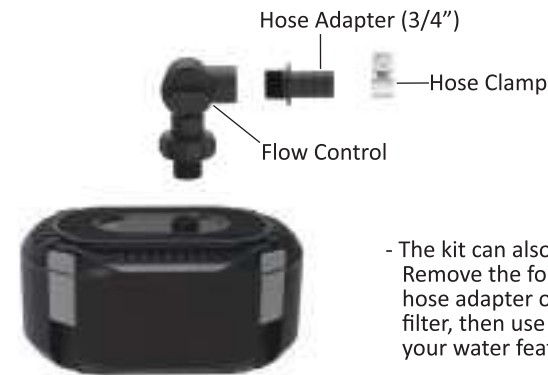

- The kit can also work as a filter individually. Remove the fountain set, screw the elbow hose adapter onto the water outlet of the filter, then use a hose to move water to your water feature (for example a waterfall).